

REFERENCIA [REFERENCE]	DESCRIPCIÓN [DESCRIPTION]	PESO [WEIGHT]		PERIMETRO ACABADO [PERIMETER]	
		kg / m	[lbs / ft]	mm	[inch.]
ALÉ-172	Junquillo	0,237	0,159	145,940	5,746
ALÉ-173	Sillar y Cabezal	0,364	0,245	195,750	7,707
ALÉ-A173	Sillar y Cabezal	0,340	0,229	193,460	7,617
ALÉ-B173	Sillar y Cabezal	0,304	0,204	197,370	7,770
ALÉ-C173	Sillar y Cabezal	0,281	0,189	200,520	7,894
ALÉ-174	Jamba	0,439	0,295	229,660	9,042
ALÉ-A174	Jamba	0,403	0,271	233,640	9,198
ALÉ-B174	Jamba	0,359	0,241	234,920	9,249
ALÉ-175	Adaptador	0,304	0,204	163,630	6,442
ALÉ-A175	Adaptador	0,281	0,189	166,060	6,538
ALÉ-B175	Adaptador	0,253	0,170	167,920	6,611
ALÉ-B175M	Adaptador	0,222	0,149	146,350	5,762
ALÉ-176	Marco Nave	0,627	0,422	226,950	8,935
ALÉ-A176	Marco Nave	0,504	0,339	230,240	9,065
ALÉ-177	Junquillo	0,193	0,130	118,360	4,660
ALÉ-A177	Junquillo	0,189	0,127	118,690	4,673
ALÉ-B177	Junquillo	0,166	0,112	123,980	4,881

NOTA: Las dimensiones en milímetros son exactas. Las dimensiones en pulgadas son aproximadas.
NOTE: Sizes in millimeters are exact. Dimensions in inches are approximate.

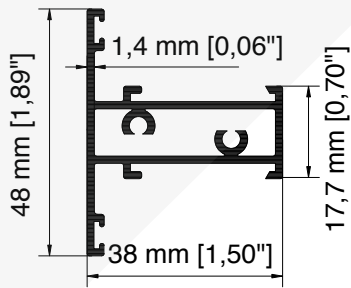

ALÉ-292

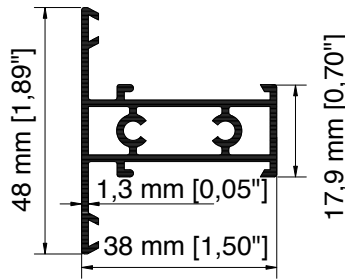

ALÉ-292M

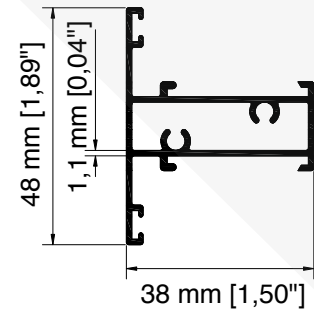

ALÉ-292R

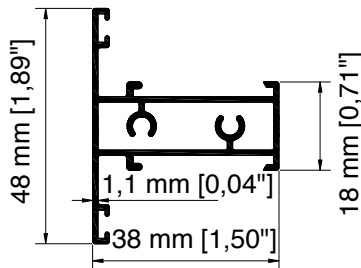

ALÉ-A292

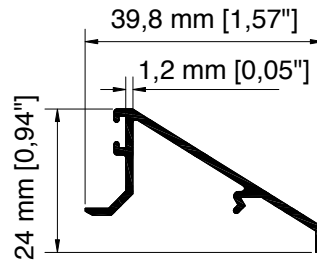

ALÉ-303M

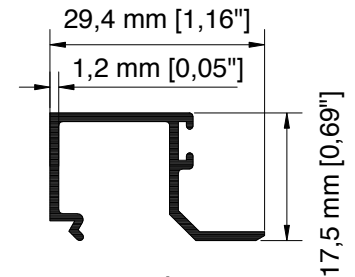

ALÉ-414

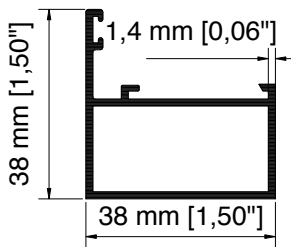

ALÉ-416
ALÉ-A416

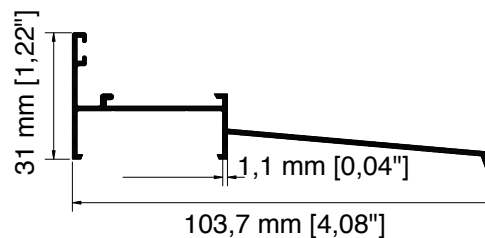

ALÉ-616

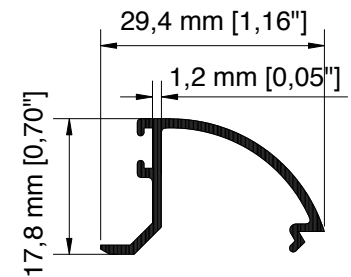

ALÉ-635

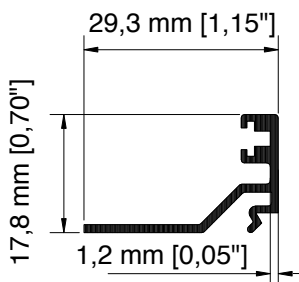

ALÉ-E497M

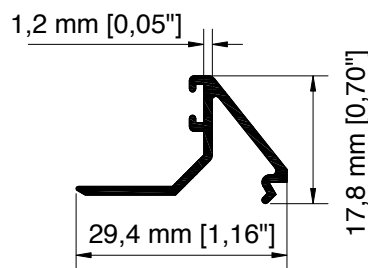

ALÉ-E544

REFERENCIA [REFERENCE]	PESO [WEIGHT]		PERIMETRO ACABADO [PERIMETER]	
	kg / m	[lbs / ft]	mm	[inch.]
ALÉ-292	0,690	0,464	229,980	9,054
ALÉ-292M	0,668	0,449	224,440	8,836
ALÉ-292R	0,552	0,371	233,290	9,185
ALÉ-A292	0,578	0,389	233,290	9,185
ALÉ-303M	0,243	0,163	148,660	5,853
ALÉ-414	0,220	0,148	139,100	5,476
ALÉ-416	0,542	0,364	181,280	7,137
ALÉ-A416	0,498	0,335	179,060	7,050
ALÉ-616	0,523	0,352	338,130	13,312
ALÉ-635	0,195	0,131	123,240	4,852
ALÉ-E497M	0,211	0,142	125,940	4,958
ALÉ-E544	0,190	0,128	120,410	4,741

NOTA: Las dimensiones en milímetros son exactas. Las dimensiones en pulgadas son aproximadas.
NOTE: Sizes in millimeters are exact. Dimensions in inches are approximate.